



# Republic Regenerative Blower HRB 902

REPUBLIC

Blower Systems®

Republic offers a complete line of regenerative blowers for high vacuum or compressed air applications in both horizontal and vertical mounted positions. TEFC motors are UL, cUL and CE certified. The impeller is directly connected to the motor shaft, providing powerful air force without undue friction. The bearings are outside the compression chamber, ensuring maximum operational reliability under high differential pressure. This low-maintenance, oil-free design provides continuous, dependable service to our customers.

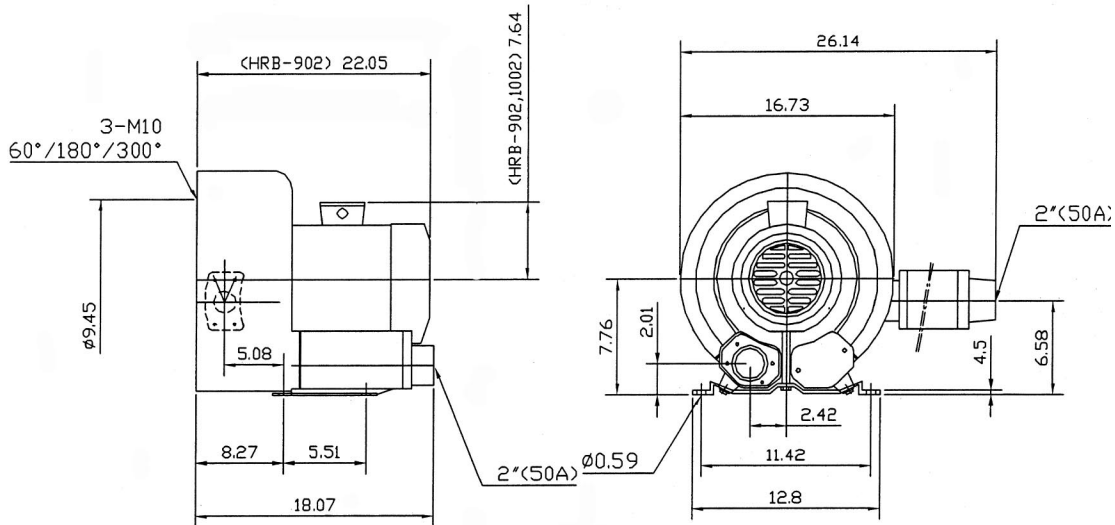
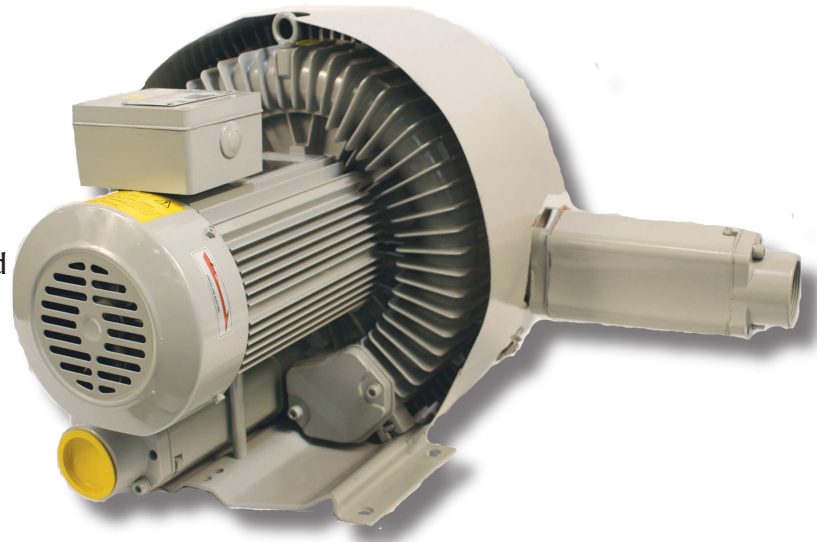

## Advantages

- ▲ Low noise 80dB
- ▲ Continuous, low-maintenance operation
- ▲ Saves space and electricity
- ▲ Trouble-free installation
- ▲ Easy replacement of parts
- ▲ Outboard bearings yielding longer life

## Product Options

- ▲ 2" Relief Valve (recommended)
  - ▲ Inlet Filter (recommended)
  - ▲ Liquid filled gauge
  - ▲ Check Valve
  - ▲ Belt-driven bare shaft blowers are available
  - ▲ Explosion proof motors available
- (Class 2/GroupB/Division 1 Certified)

Model	Phase	Motor (HP)	Current @230 V	Sound Level (dB)	Rated Pressure (in. H <sub>2</sub> O)	Rated Vacuum (in. H <sub>2</sub> O)	Air flow (cfm)	Weight (lbs)
HRB902	3	8.5	22	80	197	170	215	172



# Republic Regenerative Blower **HRB 902**

**REPUBLIC**  
Blower Systems®

**Pressure vs. CFM**

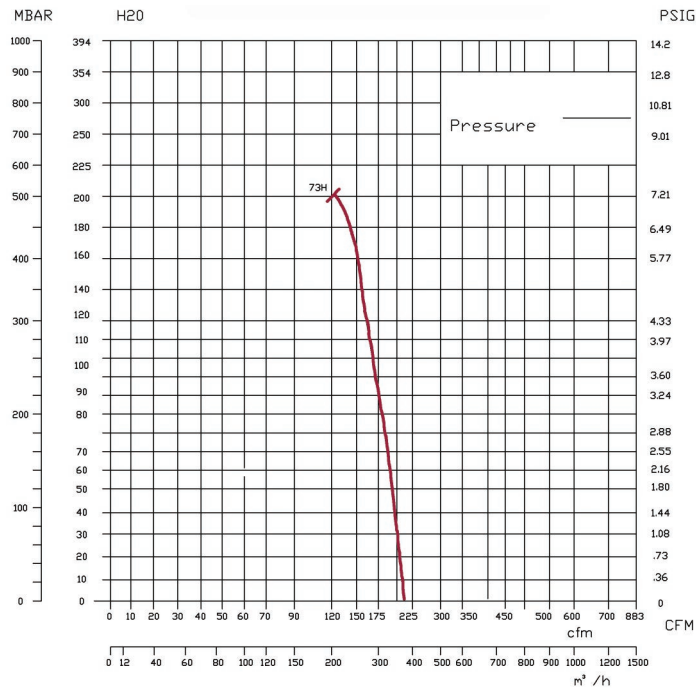

**Vacuum vs. CFM**

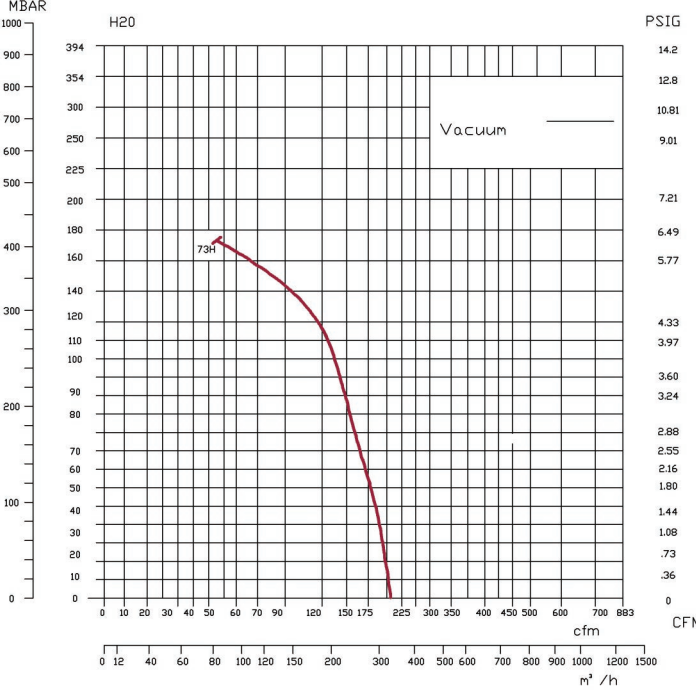

Performance for all blowers is 60 Hz. Ask for information on 50 Hz.

All Republic Regenerative Blowers are available in preassembled kits for either pressure or vacuum applications. These kits include an inlet filter and relief valve, and have been tested prior to shipment. Optional items for these kits include check valve and gauge.

**KPHRB902 - Pressure Kit Drawing**

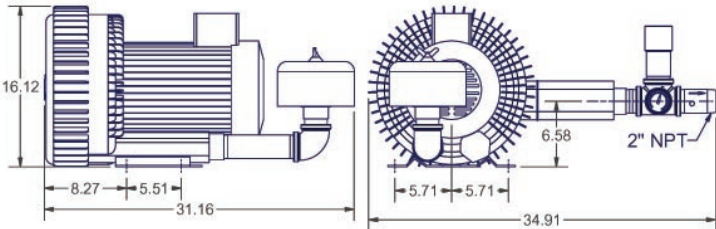

Kit Pressure 2" NPT      KPHRB902

**KVHRB902 - Vacuum Kit Drawing**

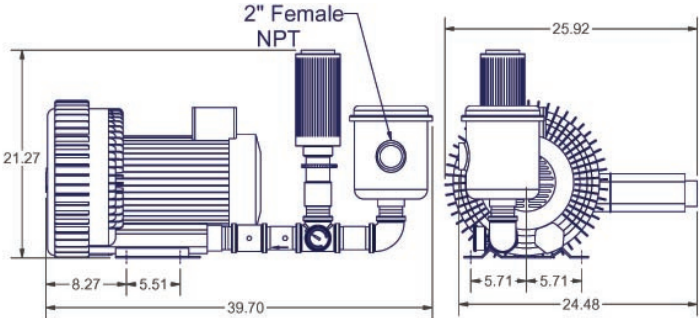

Kit Vacuum 2" NPT      KVHRB902

5131 Cash Road ▲ Dallas, TX 75247 ▲ P 214.631.8070 ▲ F 214.631.3673 ▲ 800.847.0380

[www.republicsales.com](http://www.republicsales.com)

©Republic Blower Systems®  
Created 03.06